

RVS-8 Eight Channel Repeater Voting System

Manual Version 1.0



LDG Electronics

1445 Parran Road, PO Box 48
St. Leonard MD 20685-2903 USA

Phone: 410-586-2177

Fax: 410-586-8475

ldg@ldgelectronics.com

www.ldgelectronics.com

RVS-8 Eight Channel Repeater Voting System

Introduction	3
Specifications	3
Overview	4
Installation	6
Setup	7
Operation	9
Application Notes	11
Care and Maintenance	13
Technical Support	14
Warranty and Service	14
Firmware Upgrades	14
Feedback	14

Introduction

Congratulations on selecting the RVS-8 voter. This system allows you to add up to eight satellite receivers to your repeater system. It selects the one with the best signal-to-noise ratio and channels the audio and Carrier Operated Relay (COR) output to your repeater input. A wide variety of options is available via the front-panel controls and display. You can even "cascade" up to eight of these units for a system of 64 satellite receivers.

LDG pioneered the automatic, wide-range switched-L tuner in 1995. From its laboratories near the nation's capitol, LDG continues to define the state of the art in this field with innovative automatic tuners and related products for every amateur need.

Specifications

- 8 Channels (expandable)
- True Signal-to-Noise Voting
- Microprocessor Controlled
- Software Upgradable
- Menu Driven, 10 Menus
- Programmable COR and Disable Inputs
- Programmable Hysteresis
- Digital S/N Meter
- Frequency response 30 to 20,000 Hz
- Crosstalk > 60db
- Distortion < 1 db
- Power requirement: 12 Volts DC @ 500 ma
- Board Size: 6 x 9 inches
- Rack Size: 1 Rack unit, 7 inch depth
- Enclosure size: 19 x 7.0 x 1.25 (measured in inches)

IMPORTANT SAFETY WARNING

Never install antennas or transmission lines over or near power lines. You can be seriously injured or killed if any part of the antenna, support or transmission line touches a power line. Always follow this antenna safety rule: the distance to the nearest power line should be at least twice the length of the longest antenna, transmission line or support dimension.

Overview

Your RVS-8 repeater system is a quality, precision instrument that will give you many years of service; take a few minutes to get to know it.

Your RVS-8 is designed to be mounted in a standard 19" rack. The front panel is integrated with the rack mount. Your RVS-8 comes fully assembled, tested and aligned, and is ready to install and use.



Front panel controls include:

- Power On/Off
- Power indicator LED
- COR operation LED
- Menu button
- Parameter selection button
- Data input button



The LDC display shows current system status information, and menu options when selected.



On the rear panel are connections for audio and COR inputs from up to eight receivers, COR switching output, voted audio output, and DC power input. Other useful outputs are also provided; see Installation.

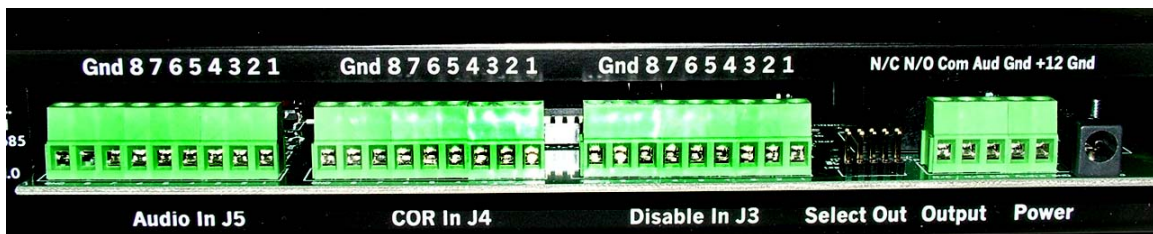

Installation

Your RVS-8 is intended for indoor use only; it is not water resistant. If you install it in a remote location, you must insure that it is protected from moisture and temperature extremes.

1. Connect the audio output from each of your receivers to the screw connections on the header labeled "Audio In J5". Each audio input is relative to the ground connection on that header.
2. Connect the corresponding COR output from each receiver to the respective screw connections on the header labeled "COR In J4". Be sure to correctly match the COR inputs to the audio inputs on J5; that is, COR 1 matches audio 1, etc.
3. If you wish, you can remotely disable receivers via the inputs on the header labeled "Disable In J3". To remotely disable a receiver, set the corresponding contact on J3 to either a high or low voltage state, depending on how you set up that channel in the menu; see Setup. You can disable as many receivers in this manner as you wish.
4. The header labeled "Select Out" provides an output indicating which of the eight receivers is voted. One of the eight pins on this header will be at +12vdc indicating the voted receiver. The other pins will be at zero volts. +12vdc at 10ma is also provided on this header. All voltages are relative to the ground connection on this header. You might use this output to drive an array of LEDs so you could see which receiver is voted from a distance. Use of these outputs is optional; you may simply leave them disconnected if you wish.

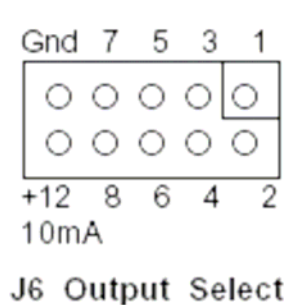

5. The main voter outputs are on the header labeled "Output". Audio output and its dedicated ground are the rightmost two connectors on this header. COR output is the leftmost three, providing normally closed, normally open and common connections. The COR outputs are "dry" contact closures; no voltages are output on these connectors.
6. DC power input is via the coaxial connector labeled "Power". Connect this to a source of 12 volts DC capable of providing at least 500 ma, using the provided 2.5 by 5.5 mm coaxial plug. Best practice is a regulated DC power supply connected to the AC line through a high-quality surge protector.

Setup

Setup your RVS-8 via the front panel buttons and LDC display. Setup data is stored in non-volatile EEPROM, and remains intact when power is removed.

Hysteresis

The hysteresis level is the amount of signal-to-noise ratio improvement needed over the currently voted site for a new site to be voted. Press the **Menu** button until the present hysteresis value is displayed. Press the **Data** button to select the desired value. Available values are 0 - 8. You should adjust this to a higher value if you experience excessive switching between receivers. A higher value requires more improvement in the signal-to-noise ratio for switching to occur. The normal value should be 3 or 4.



Disabled Channels

Press the **Menu** button until the presently disabled channels are displayed. To disable or enable a channel, press the **Selection** button to scroll across to the desired channel. Press the **Data** button to toggle between enabled and disabled. The channel is disabled when the channel number appears in the Disabled Channels display.

This display also reflects channels disabled via hardware connected to J3. Channels disabled in software via this menu cannot be enabled via hardware, and vice versa.

Be sure not to disable all channels. This would effectively turn off the repeater as no inputs would be passed through.

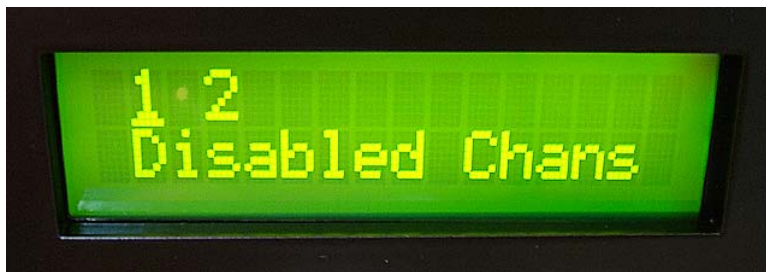

Disable Active State

You can choose whether a receiver is disabled by means of a high or low voltage state input to J3. This selection can be made for each channel; that is, you can set each channel to either high or low separately. Press the **Menu** button until the "Dis Active State" menu is displayed. Press the **Selection** button until the desired channel is displayed, then press the **Data** button to select high (HI) or low (LO).

Active HI means your controller or other external device must produce a positive-going voltage (6.5 to 20 volts) when the channel is to be disabled, and a low-going voltage (0.0 to 4.5 volts) when the channel is to be enabled. Active LO means that your controller or other external device must provide a low-going voltage (0.0 to 4.5 volts) when the channel is to be disabled, and a high going voltage (6.5 to 20 volts) when the channel is to be enabled.



COR Active State

You can choose whether a high or low voltage state indicates an active COR input on J4. This selection can be made for each channel; that is, you can set each to channel to either high or low separately. Press the **Menu** button until the "COR Active State" menu is displayed. Press the **Selection** button until the desired channel is displayed, then press the **Data** button to select high (HI) or low (LO).

Active HI means that your receiver COR must produce a positive-going voltage (6.5 to 20 volts) when the squelch is open (receiving a signal) and a low-going voltage (0.0 to 4.5 volts) when the squelch is closed (no signal). Active LO means that your receiver COR must provide a low-going voltage (0.0 to 4.5 volts) when the squelch is open and a high-going voltage (6.5 to 20 volts) when the squelch is closed.



Operation

On power-up, the display shows a title screen and current firmware version for a few seconds, then the default screen: "Current Voted". The currently voted receiver is displayed. As the repeater operates, the red COR LED on the front panel will light when the repeater is activated. The Current Voted display continuously updates as the system switches from receiver to receiver.



Several other useful items of information are available on the LCD display. Press the **Menu** button to display the following:

Current CORs: displays the CORs that are presently active, showing a received signal on that receiver.



Signal / Noise: displays the signal to noise ratio of each channel. Press the **Selection** button to view this information for each channel (receiver). The value displayed is between 0 and 255, with 255 representing the highest ratio (also the best signal).



Most Voted: Displays the channel most often voted, out of the last 100 COR cycles. This count is reset when DC power is cycled.



Least Voted: Displays the channel least often voted, out of the last 100 COR cycles. This count is reset when DC power is cycled.



Hits per Chan: Displays the number of times each channel was activated out of the last 100 COR cycles. The value will be between 0 and 100. This count is reset when DC power is cycled. Press the **Select** button the view data for each channel.



Application Notes

The following diagram shows a basic setup with eight satellite receivers. Typically, one of the receivers is the "main" receiver, co-located with the transmitter. The other receivers are usually "link" receivers bringing audio from remote satellite receivers.

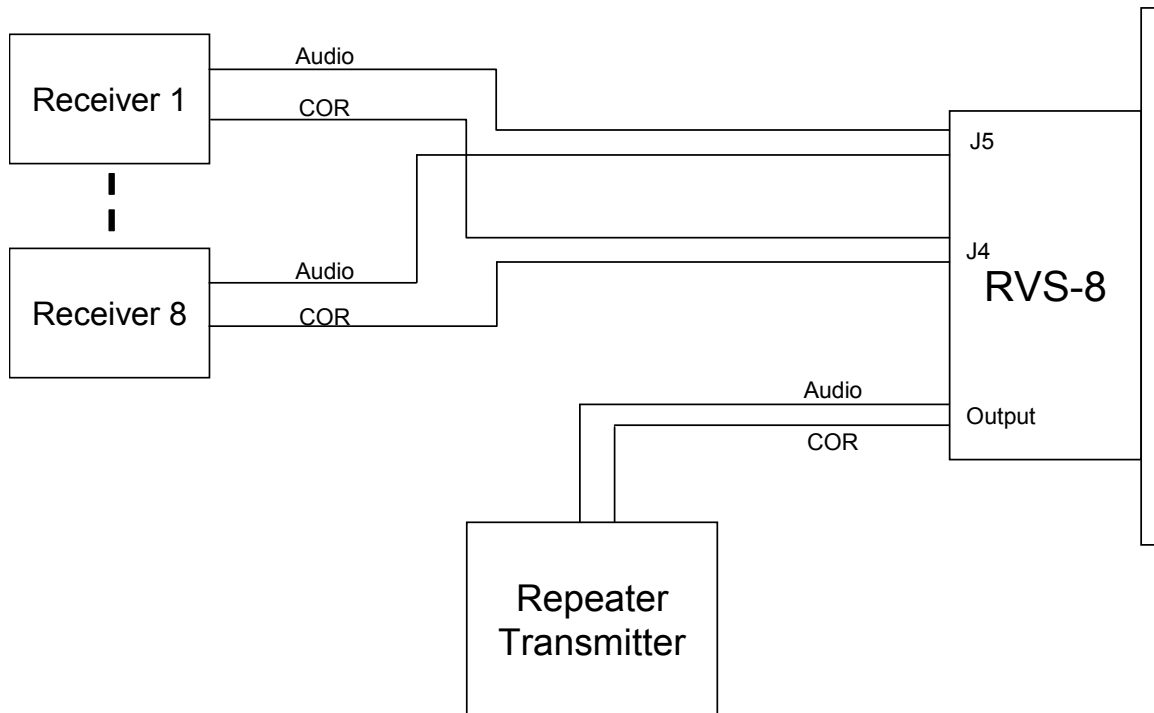

Should the need arise, you can use up to 64 satellite receivers by "cascading" eight RVS-8 voters. Each of the eight voters can input eight receivers, for a total of 64. The outputs of these eight RVS-8 voters are then input to a ninth RVS-8 unit which provides final selection of audio and COR outputs to the repeater transmitter. Frankly, if you're using 64 satellite receivers, you've got *our* respect.

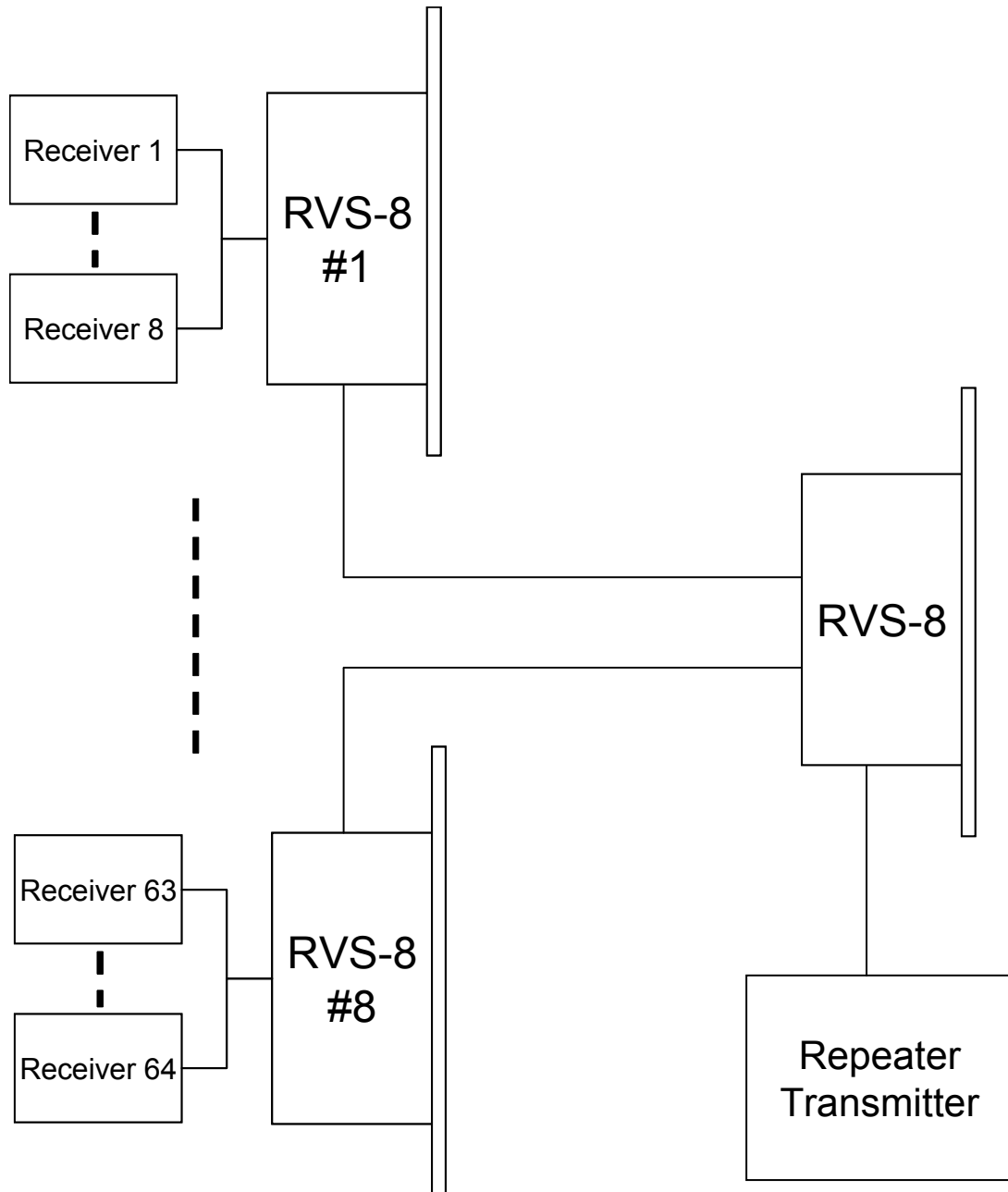

Alignment

The first step in alignment is to make sure that each channel is matched to the proper COR and Disable Active State. Test each input to make sure that when the COR becomes active on your receiver, the voter responds properly and shows that channel as having an active COR.

The calibration process is fairly simple. Start with the eight audio pots and eight noise pots centered. Each channel will be calibrated in the same manner, so only the first channel will be discussed and the user can then calibrate the other channels as needed.

An RF signal generator and oscilloscope will be useful in the alignment process, but you can be creative with other test equipment and achieve proper calibration.

Start by transmitting an on-frequency signal of 1000 Hz at 3.0 KHz deviation to your first remote receiver. Be sure that the signal is full quieting. Place the scope on test point AUD1 and adjust the AUD1 pot for 1.0 volts peak to peak.

Remove the test signal and open the squelch of the first remote receiver. Place the scope on test point Noise1 and adjust the Noise1 pot to read 3.5 volts.

Repeat for channels 2 through 8, or for the number of channels used.

The Audio Out pot is used to set the overall output level of the voter.

Tips

If you don't have a signal generator, you can use a transceiver and press the touch tone pad to generate a tone signal. This can be used to get the voter adjustments close.

If you have a difficult time getting the Noise adjustment down to 3.5, lower the AUD adjustment to 0.5 volts peak to peak. If you do this, make sure that all receivers are set to 0.5 volts. As long as all inputs are set to the same voltage level, you can lower the signal down to 0.2 volts peak to peak if needed.

The type of audio used from the receivers can be just about any type as long as all of the receivers use the same audio. Audio types that are acceptable are line level and speaker audio. Also, it does not matter if the audio is de-emphasized or not as long as all of the receivers are the same.

The biggest problem seen in getting the voter to work properly is a mis-match in the audio characteristics between the receivers. Many times, doing a frequency sweep will expose differences in the audio response. Since there are literally dozens of different receivers that you could use, there could be dozens of different audio responses possible. Usually the best way to get near identical audio responses is to use the same brand and model of the remote and link receiver.

Care and Maintenance

Your RVS-8 voter is maintenance-free. As with any modern electronic device, your RVS-8 can be damaged by water, temperature extremes, impact or static discharge.

Technical Support

We are happy to help you with your RVS-8. Telephone technical support is available at 410-586-2177 weekdays from 9 am to 5pm Eastern Time. Inquiries by Fax at 410-586-8475 are welcome, and prompt e-mail support is available at ldg@ldgelectronics.com.

Warranty and Service

Your RVS-8 is warranted against defects in parts or workmanship for two years from purchase. The warranty does not cover damage due to abuse or exceeding specifications. This warranty applies to the original purchaser only; it is not transferable. A copy of the receipt showing the purchaser's name and the date of purchase must accompany units returned for warranty service. All returns must be shipped to us pre-paid; we will not accept units with postage due. A return form is provided on our web site for your convenience.

If you need to return your RVS-8 to us for service, package it carefully, keeping in mind that we will re-use your packaging to return the unit to you. Download the return form from our web site (ldg@ldgelectronics.com), fill it out and return it with your voter. A self-addressed return-shipping label, while not required, will help insure speedy and accurate delivery of your repaired unit. Include a full description of the problem, along with your name, address and a phone number or e-mail address where we can reach you with any questions. Repairs average about 3 to 6 weeks.

We will be glad to service your RVS-8 after the warranty period has ended. We will notify you of repair charges by phone or e-mail, and bill you after repairs are completed.

Firmware Upgrades

From time to time LDG may release upgraded firmware for the RVS-8, refining operation and adding features. Your RVS-8 is not field programmable; you will have to remove the present chip and replace it with the upgrade chip. Upgrades are expected to cost about \$10-\$20, and will be announced on our web site when available.

Feedback

If you have an idea to improve our software or hardware, please send us a description. If we incorporate your idea in the RVS-8, we'll send you a free upgrade as a "thank you".

We encourage everyone who uses the RVS-8 to contact us (card, letter or e-mail preferred) telling us how well it works for you. We are also always looking for photographs of our products in use; we frequently place such pictures on our web site (www.ldgelectronics.com).



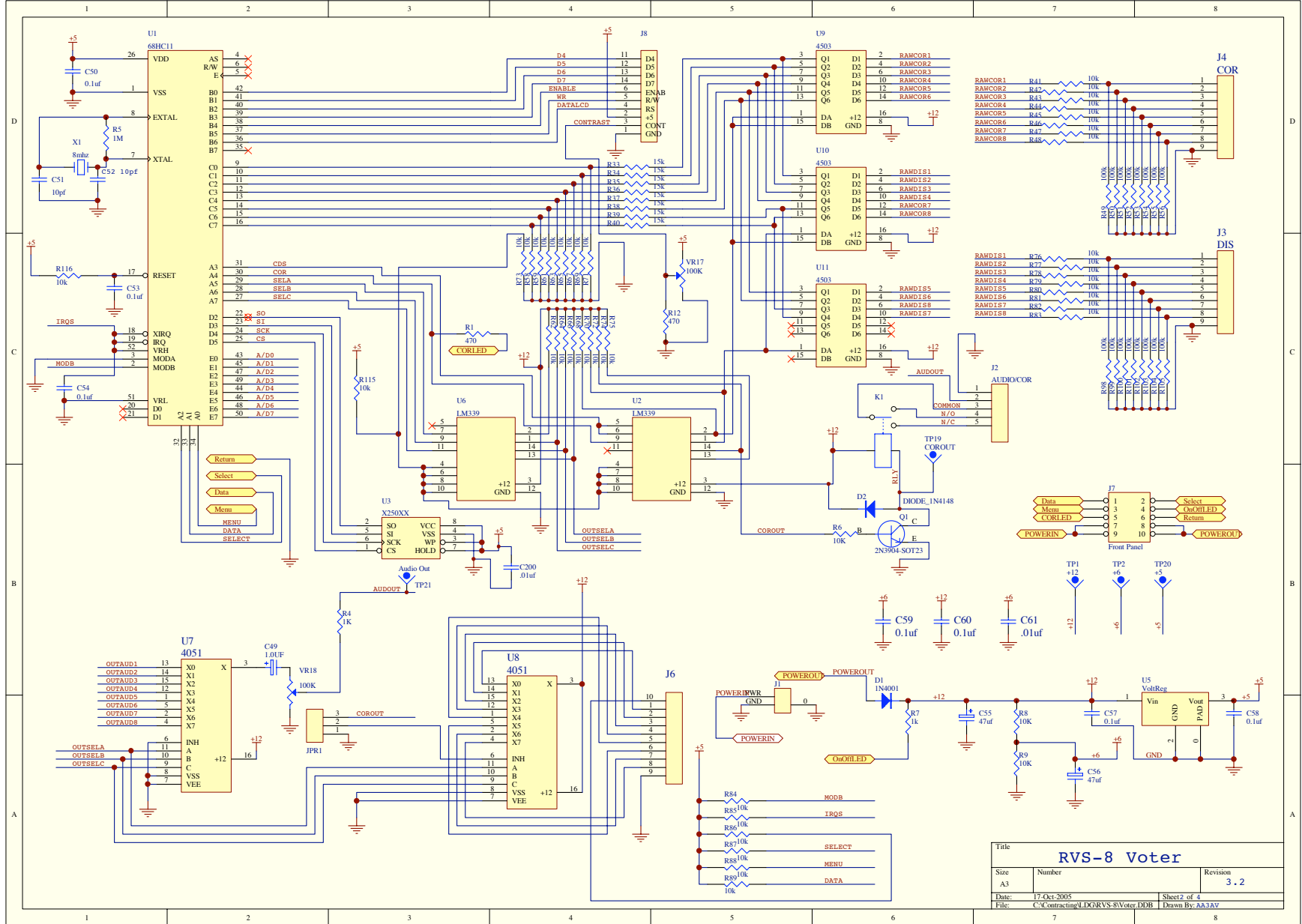

Title		
RVS-8 Voter		
Size	Number	Revision
A3		3.2
Date:	17.Oct.2005	Sheet 2 of 4
File:	C:\Contracting\LDGRVS-RVoter.DDB	Drawn By: AA3AV

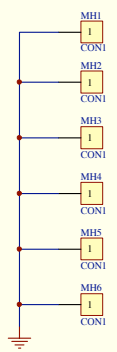
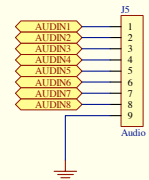
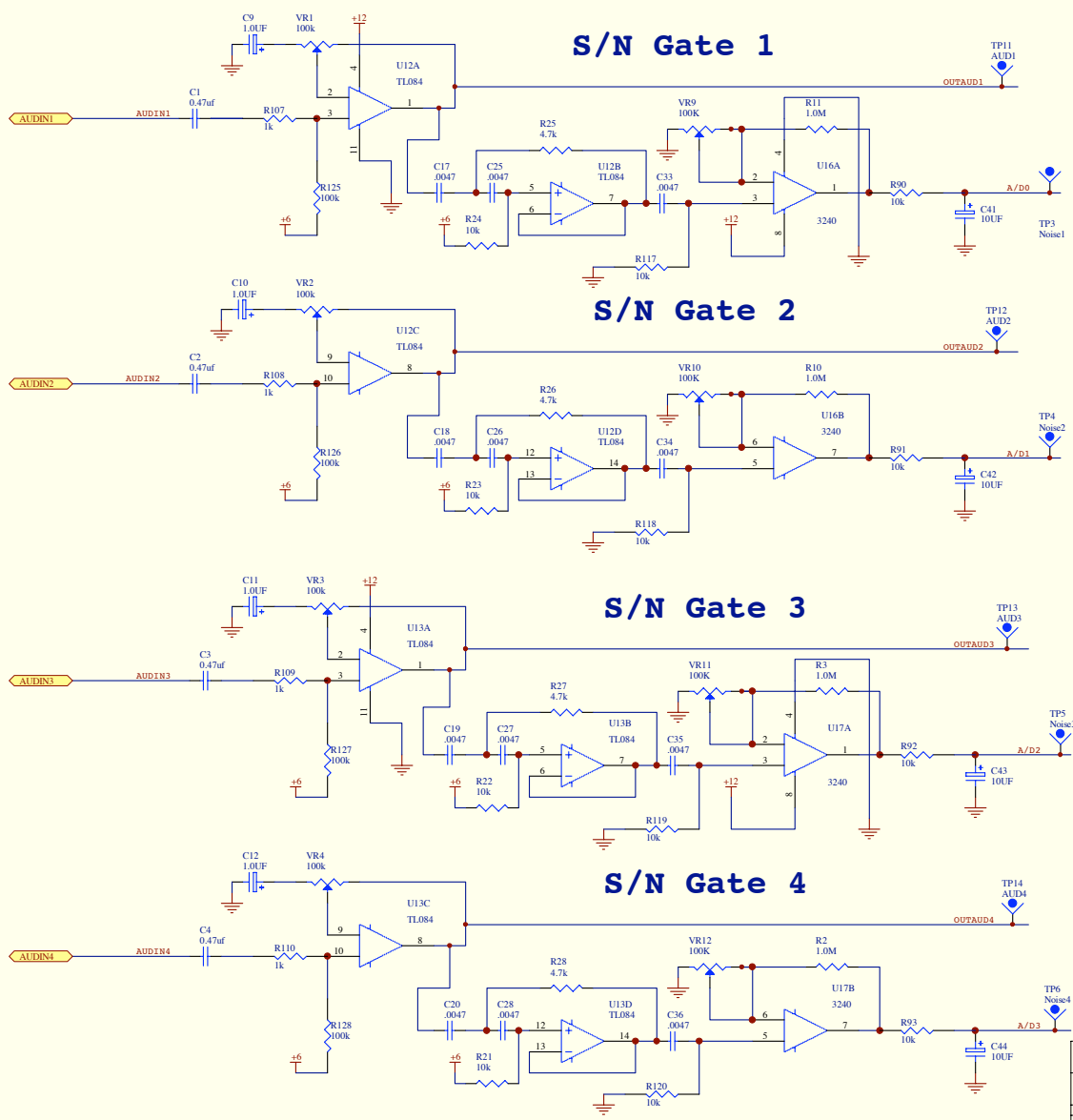

Title			RVS-8 Voter		
Size	Number	Revision			
A3		3.2			
Date:	17.Oct.2005	Sheet 3 of 4			
File:	C:\Contracting\LDGRVS-S\ Voter.DDB	Drawn By: AB,3AV			

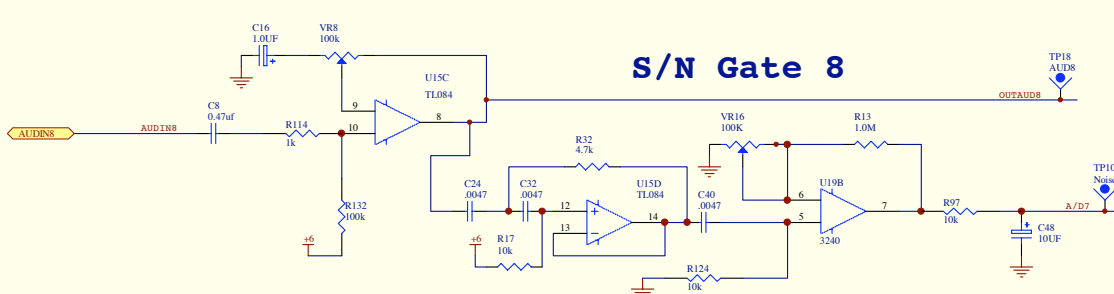
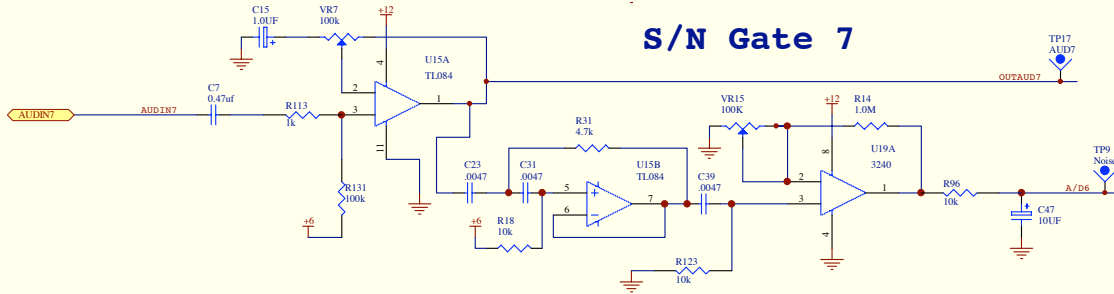
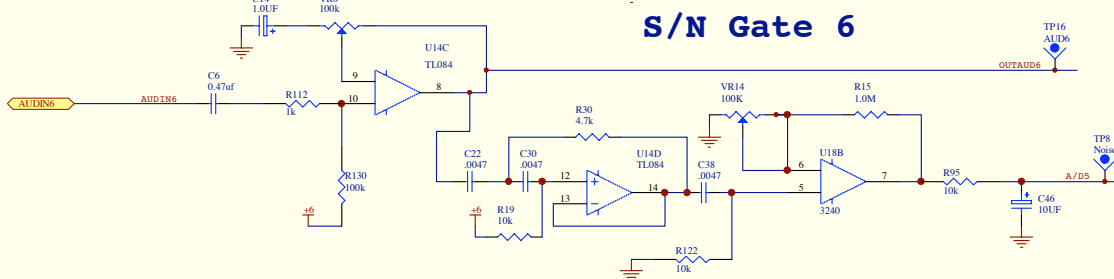
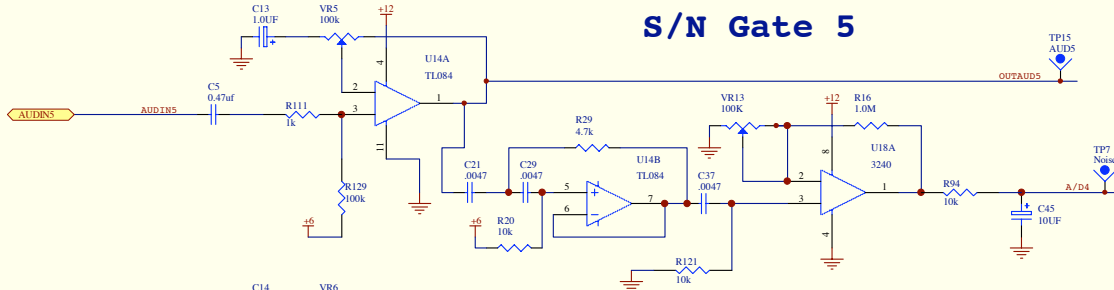

Title		
RVS-8 Voter		
Size	Number	Revision
A3		3.3
Date:	17.Oct.2005	Sheet 4 of 4
File:	C:\Contracting\LDGRVS-S\ Voter.DDB	Drawn By: AA3AV

040 (m.1)

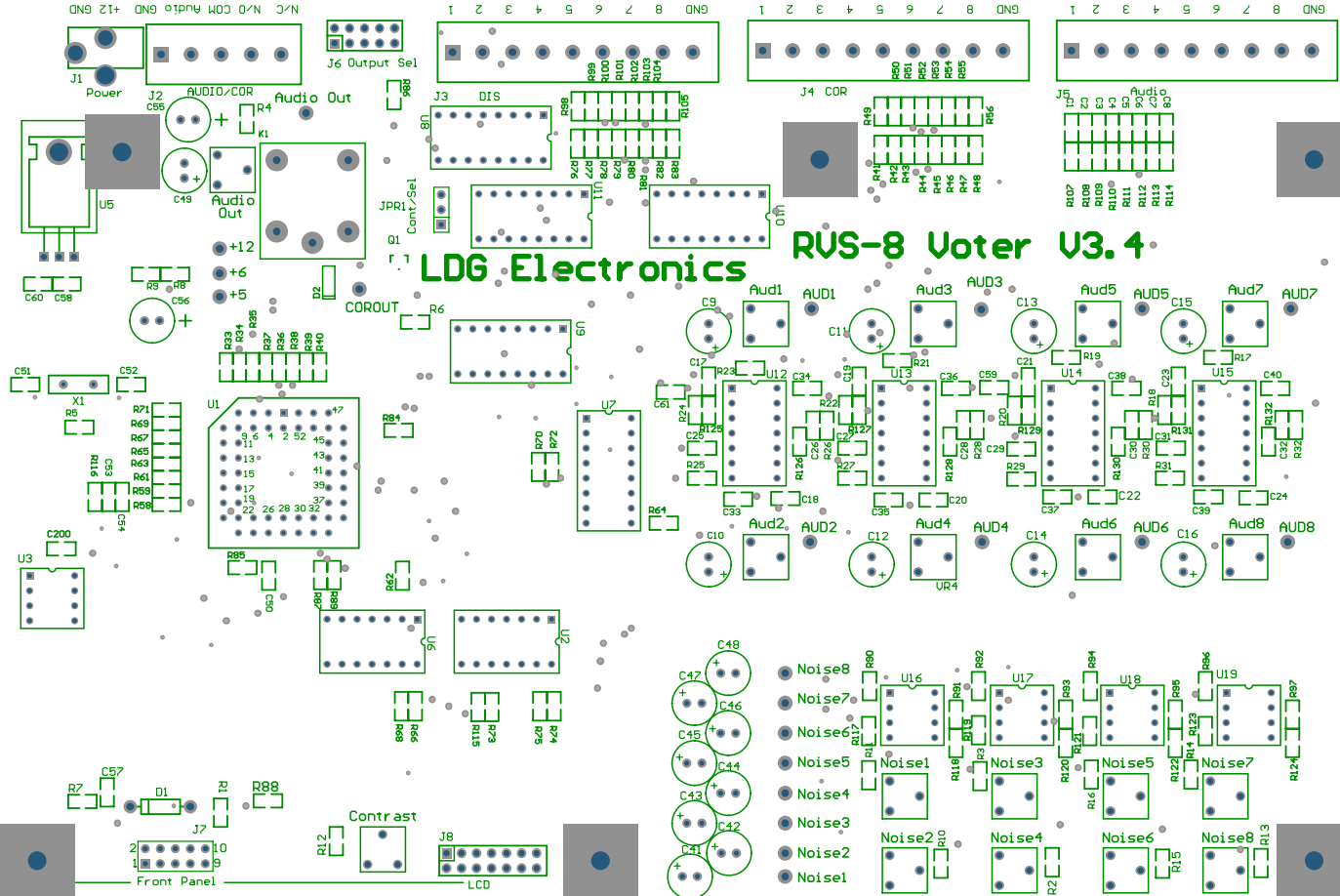

LDG Electronics RVS-8 Voter V3.4

